



## ENC-08DN/16DN/24DN/32DN



High quality damper actuators have been designed for use with air damper, butterfly valve, characterized ball valve and globe valve with the use of special adapter.

### Features

- Universal Spindle Clamp for easy direct mounting
- Anti-rotation bracket provided for stability
- Manual over ride by push button when required
- Adjustable angle of rotation
- Parallel connection up to 10 actuators
- 2 adjustable SPDT auxiliary switches **when requested**
- Power saving at end stops
- Customized version available, on request

### Mounting dimensions

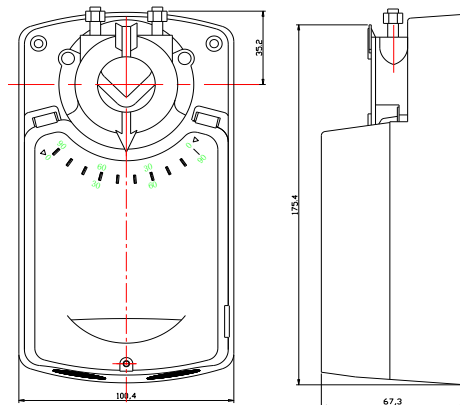

Size(mm)

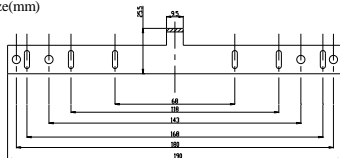

### Specifications

Item	ENC-08DN	ENC-16DN	ENC-24DN	ENC-32DN
Torque	8Nm	16Nm	24Nm	32Nm
Damper area	1.5m <sup>2</sup>	3m <sup>2</sup>	4.5m <sup>2</sup>	6m <sup>2</sup>
Running Time	45S	110S	160S	180S
Power supply	AC-24V / DC-24V			
Frequency	50/60Hz			
Power consumption	Operating: 4.0W			
Wiring size	0.5m <sup>2</sup>			
Shipping weight	1.1Kg (24V)			
Control signal	2point and 3point			
Rotation angle	0~90°			
Limit angle	5~85°(5°increment)			
Auxiliary switch	3 (1.5) Amp 230V <b>when request</b>			
Life cycle	60,000 cycles			
Noise level	45dB(A)			
Protection class	<b>II</b>			
IP protection	IP54			
Ambient temperature	-20~+50°C			
Ambient humidity	5~95%RH			
Storage	-40~+70°C			
Certificate	CE and ISO9000			

**Wiring diagram**

2-point

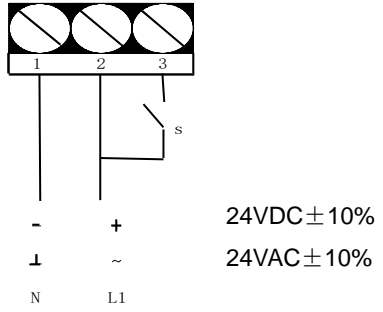

3-point

